

BRSO326HP1632+

Revisions	Date	Description	By
-	2022/01/19	INITIAL ISSUE	dr

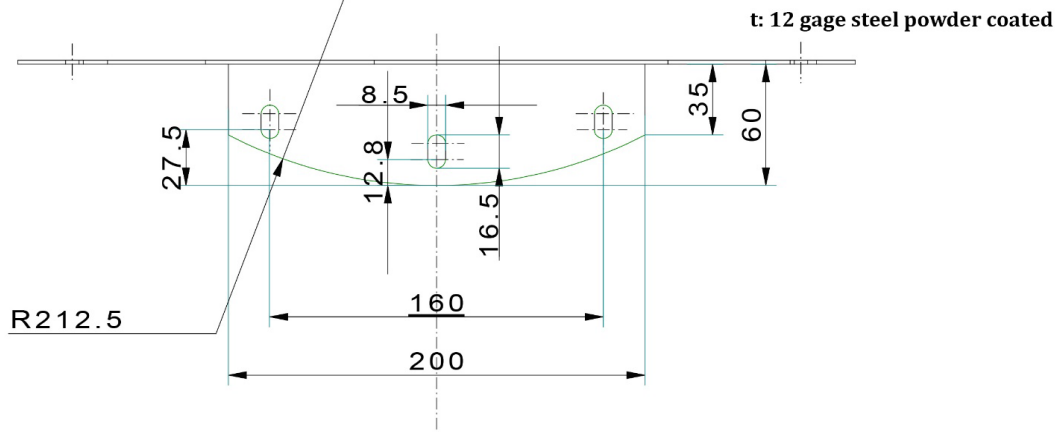
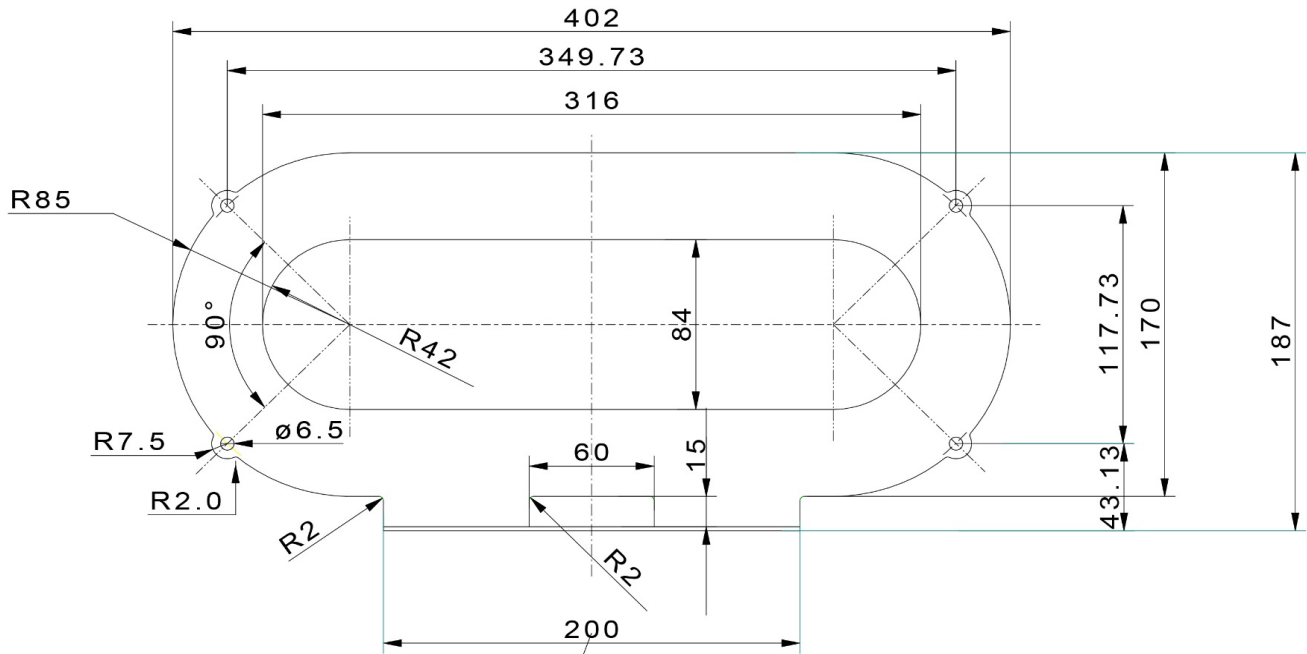

NOTES:

1. ALL EDGES TO BE FREE OF BURS
2. BEND CUT OUT FEATURE NOT CRITICAL
3. TOLERANCES +/- 0.127 UNLESS OTHERWISE STATED.

Dimensions in mm	Formerly MS-248-PE	Drawing Number: BRSO326HP1632+	
Clamp Material: HRPO-CQ steel 12 gage		Country of Origin: U.S.A.	
MH&W International Corp Phone 201-891-8800 Email: sales@mhw-intl.com		Finish: Powdercoat Polyester	TCI 9510-91410
		Part Number: BRSO326HP1632+	